

PITBULL® MODEL S2V 2" SUBMERSIBLE PUMP

The model S2V is a nonmetallic submersible pump designed to operate reliably in difficult sump environments. It is fully automatic and will operate with either the AP300 (all-pneumatic) or EP250 (electro-pneumatic) control panel. Both panels are available with flow inducement (suction fill) options.

Solids capacity is 1.25" in diameter, which allows the S2V to pump medium levels of debris/solids in highly corrosive conditions. The S2V can pump a very wide range of chemicals at heads up to 100 psi.

The S2V handles all manner of chemical sumps with acids ranging from hydrochloric, sulfuric, nitric, and phosphoric to sodium hydroxide and sodium hypochlorite. In addition to in-plant sumps, areas like tank car unloading, tank farms, and secondary containment dikes, hazardous and remote locations are among the many types of service suitable for these units.

When equipped with the flow inducement option a S2V can pull sump levels down to almost sump floor level, minimizing the standing liquid volume.



Dimensions
[mm]
inches

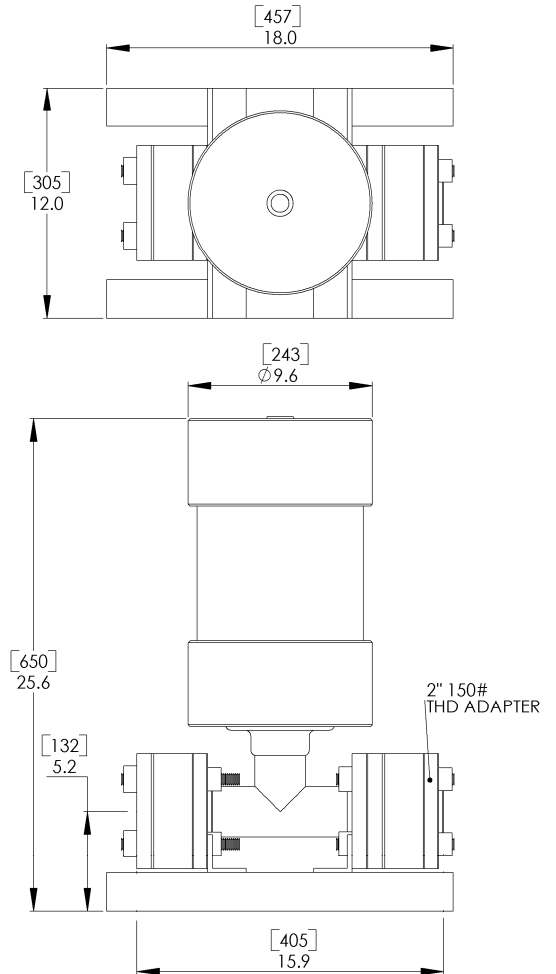

SPECIFICATIONS

- Inlet-open, Outlet- 2" NPT flange adapter
- Weight: 54 lbs
- Operating Levels:
 - Gravity fed- 22"
 - Flow induced- 7"
 - Control Panels: AP300/AP300F2 or EP250/EP250F2
- Materials:
 - Chamber/base- vinyl ester composite
 - Check valves- polypropylene, viton
 - Fasteners- vinyl ester composite
 - Maximum solid: 1.25"
 - Maximum head: 100 psi
 - Maximum temperature: 150F

MAXIMUM FLOW CURVE

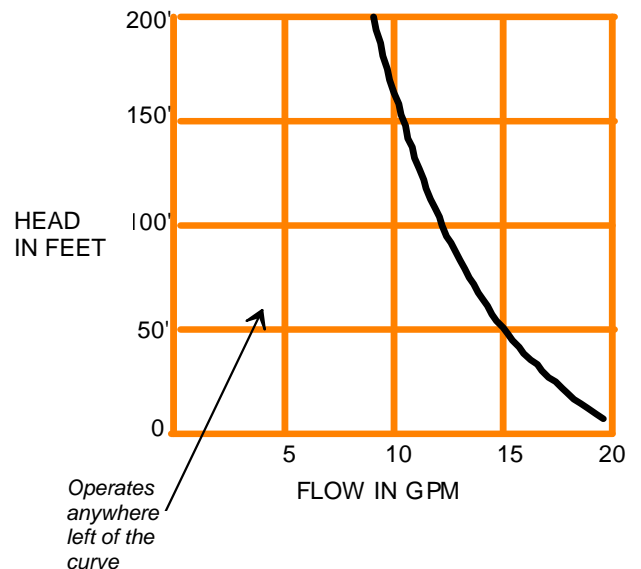

See reverse side for air consumption, ordering information and installation recommendations.
CIPC BULLETIN # SV2-11

©CIPC 2011

Model and options selection:

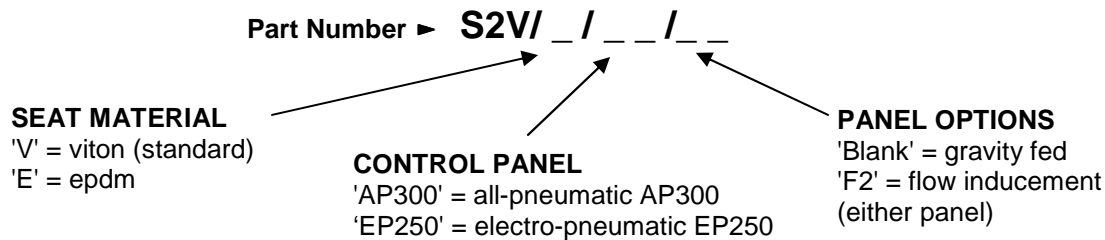

Standard units:

#S2V/V/AP300 = a vinyl ester submersible pump with polypropylene checks, viton seats and AP300 panel.

#S2V/V/EP250 = a vinyl ester submersible pump with polypropylene checks, viton seats and EP250 panel.

Optional examples:

#S2V/V/AP300F2 = a vinyl ester submersible pump with polypropylene checks, viton seats and AP300F2 panel with the F2 flow inducement (vacuum fill, low level operation) option.

#S2V/E/EP250F2 = a vinyl ester submersible pump with polypropylene checks, epdm seats and EP250F2 panel with the F2 flow inducement (vacuum fill, low level operation) option.

A complete pump contains: pump, inlet and discharge check valves, a control panel complete with filtration and autodrain, and 15' of nitrile/polyester braided airlines (2) which includes a main airline for operating the pump and a 1/2" liquid level control line.

Valve seat selection:

Viton - excellent resistance to oxidizers and solvents. Medium strength, use to 250°F.

EPDM - good heat and acid/base resistance. Tougher than viton but poor solvent resistance, use to 300°F.

Description of options:

'F2' flow inducement. This is an air powered, vacuum generator mounted to the exhaust valve of the control panel. It creates vacuum in the pump to pull fluid into the pump chamber during the 'fill' cycle. The F2 is sized for 2" and 3" pumps (**see detail below).

AP300F2 Control Panel (shown)
(EP250F2 has identical configuration)

AIR CONSUMPTION in SCFM

Applies to any pump; use max flow curve (front page) for correct range.

Head Flow	10 ft	20 ft	40 ft	60 ft	80 ft	100 ft	140 ft	180 ft	220 ft
10 gpm	2	2.4	3.2	4.1	4.9	5.8	7.5	9.3	11
20 gpm	3.8	4.7	6.4	8.1	9.9	11.6	15.1	18.5	22
30 gpm	5.7	7	9.6	12.2	14.8	17.4	22.6	27.8	33
40 gpm	7.6	9.4	12.8	16.3	19.7	23.2	30.1	37.1	44
60 gpm	11.4	14	19.2	24.4	29.6	34.8	45.2	55.6	66
80 gpm	15.2	18.7	25.6	32.6	39.5	46.4	60.3	74.1	88
100 gpm	19	23.4	32	40.7	49.4	58	75.3	92.7	110
140 gpm	26.6	32.7	44.8	57	69.1	81.2	105.5	129.7	154

Example: 20 gpm @ 20 ft TDH requires 4.7 SCFM

**Air consumption for F2 flow inducement ; take desired flow rate, divide it by the maximum flow rate at same head. Multiply this factor by 7 scfm. Add this consumption to the chart above.

Example: Desired flow is 10 gpm @ 40'. Max flow is 16 gpm @ 40'

Additional consumption = (10/16) x 7 = 4.4 scfm.

Total consumption = 3.2 (above) + 4.4 = 7.6 scfm



COMMONLY ASKED INSTALLATION/APPLICATION QUESTIONS

How much air will it actually use?

The PITBULL ® matches your incoming flow rate. So when the inflow drops to half, the air consumption is cut in half too. Actual air consumption is usually much less than shown unless inflow is constant.

Can the airlines be hard-piped?

Yes they can, but the ID's of our standard lines must be matched.

Where is the control panel mounted?

Place within the 15' radius of the airlines, above the pump. Contact CIPC for longer distances

Can the piping be reduced?

Smaller piping causes higher head and velocity, and the pump may pass things the piping can't. Try to avoid dropping more than one pipe size.