



MODEL C4C

CLASS: Hot Condensate Return

CONSTRUCTION: 304SS Chamber, Carbon Steel Base

CAPACITY: 0-82 gpm [41,000 lbs/hr]

DISCHARGE PRESSURE: 0-100 psi [6.9 Bar]

MAX SOLID: 3.75" [9.5 cm]

CONFIGURATION OPTIONS

- ALL-PNEUMATIC CONTROL (XP/explosion-proof and remote locations)
- GRAVITY FILLED
- HIGH TEMPERATURE (212F/100C)
- INCLUDES BRASS SIGHT GLASS

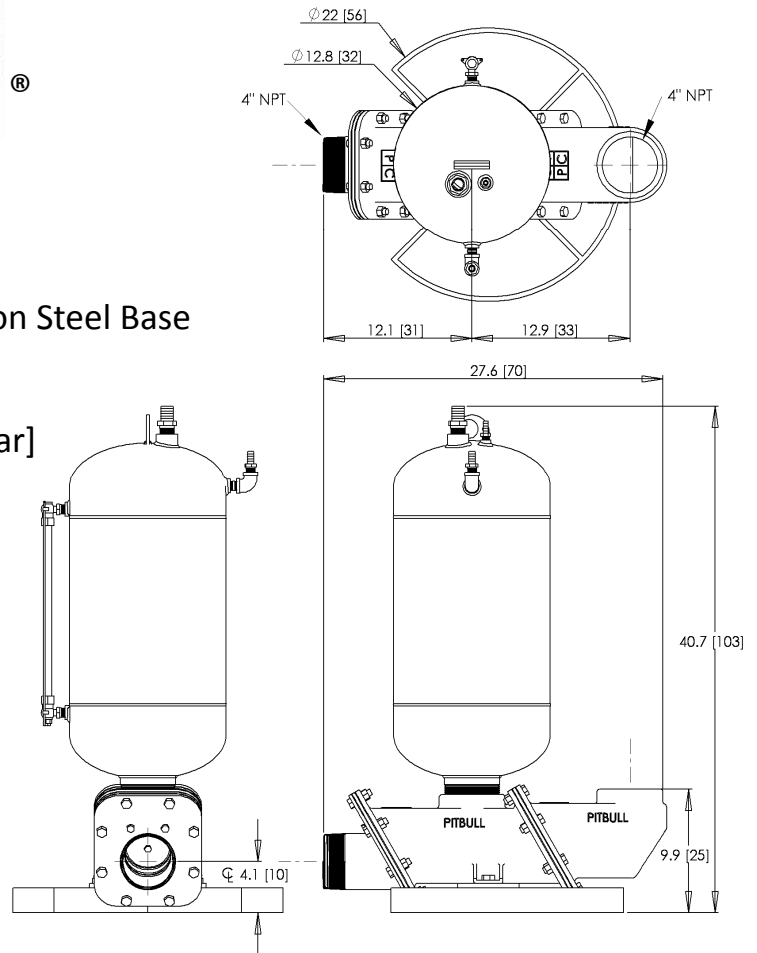

KEY FEATURES

The model C4C is a condensate return pump designed for direct connection to a flash tank/receiver and may also be used for submersed high temperature sump applications.

There are no floats, over-center devices, valve mechanisms, springs, switches or probes inside the pump to service. Instead the C4C is operated remotely and automatically by the patented, all-pneumatic AP212C control panel.

Two heavy-duty, 316SS swing check valve flappers are the only wetted, moving components.

In addition, the C4C has a 3.75" diameter solids capacity so it is not limited to clean fluids and will handle all sorts of debris and solids.

QUICK SPECS

- Weight: 184 lbs [84 kg]
- Stroke Volume: 10.3 gal [39 l]
- Operating Levels: 'Gravity' - 32" [81 cm] (see reverse side for explanation)
- Panel Required: AP212C

See reverse side for Specification Details, Flow Curve and Air Consumption



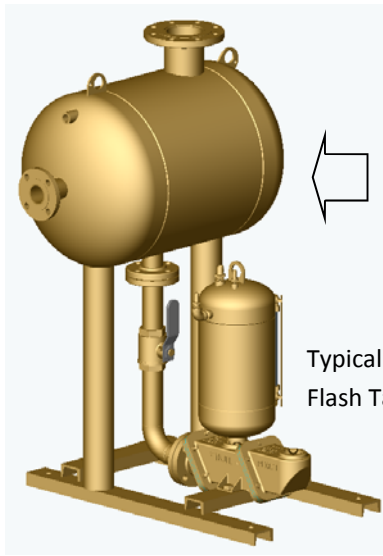

Typical Installation with Flash Tank Receiver

When pumping hot condensate the C4C pump requires that the condensate flash to atmospheric pressure before entering the pump. Shown is a typical flash tank with a large vent to release flash and enough height for condensate to drain into the pump by gravity.

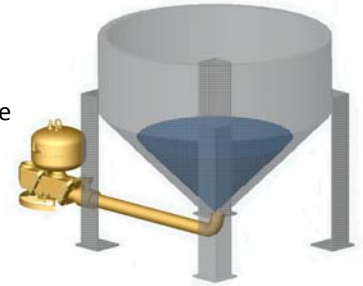

Gravity operation requires an operating level equal to the top of the pump, approximately 32" above grade (surface the pump is on). The above sketch shows a liquid level high enough to cycle the pump.

Part# C4C / _ / AP212C4

SEAT MATERIAL

- E = epdm (standard on C2C)
- V = viton
- T = teflon
- K = kynar

PANEL

Example:

C4C/E/AP212C4= 4" 304SS/steel condensate pump with epdm seats, AP212C4 control panel.

Panel Requirements: Compressed air or dry gas, unlubricated, recommended 80 psi delivered through 3/4" pipe or equal.

Valve seat selection:

- Viton - excellent resistance to oxidizers and solvents. Medium strength, used up to 250°F.
- Teflon - excellent chemical resistance to acids, bases and solvents. Lower cycle life, non-elastomeric, used up to 300°F.
- EPDM - good heat and acid/base resistance but poor hydrocarbon resistance, used up to 300°F.
- PVDF (kynar) - excellent chemical resistance, toughness and resistance to cold flow (thermoplastic). Good cycle life and can be used up to 250°F.

MAXIMUM FLOW CURVE

with air consumption in SCFM (gravity mode)

220 ft	11.0	22.0	33.0	44.0	55.0	Operating Flow Capacity:				
200 ft	10.1	20.3	30.4	40.5	50.6	anywhere in shaded area.				
180 ft	9.3	18.5	27.8	37.0	46.3	Air consumption: pick closest cell to				
160 ft	8.4	16.8	25.2	33.6	42.0	your flow & pressure match				
140 ft	7.5	15.1	22.6	30.1	37.7	45.2	52.7	60.2	67.8	75.3
120 ft	6.7	13.3	20.0	26.7	33.3	40.0	46.7	53.3	60.0	66.6
100 ft	5.8	11.6	17.4	23.2	29.0	34.8	40.6	46.4	52.2	58.0
80 ft	4.9	9.9	14.8	19.7	24.7	29.6	34.5	39.5	44.4	49.3
60 ft	4.1	8.1	12.2	16.3	20.3	24.4	28.5	32.5	36.6	40.7
40 ft	3.2	6.4	9.6	12.8	16.0	19.2	22.4	25.6	28.8	32.0
20 ft	2.3	4.7	7.0	9.3	11.7	14.0	16.4	18.7	21.0	23.4
10 ft	1.9	3.8	5.7	7.6	9.5	11.4	13.3	15.2	17.1	19.0
GPM	10	20	30	40	50	60	70	80	90	100
lbs/hr	5004	10008	15012	20016	25020	30024	35028	40032	45036	50040

AP212C Panel



Example (gravity fill): 70 gpm @ 20 ft TDH requires 16.4 SCFM