



MODEL S3X2S

CLASS: Submersed chemical and solids handling

CONSTRUCTION: Stainless Steel

CAPACITY: 0-47 gpm [179 lpm]

DISCHARGE PRESSURE: 0-100 psi [6.9 Bar]

MAX SOLID: 2" [5 cm]

CONFIGURATION OPTIONS

- ALL-PNEUMATIC CONTROL (XP/explosion-proof and remote locations)
- ELECTRO-PNEUMATIC CONTROL (non-XP)
- GRAVITY FILLED
- FLOW INDUCED (vacuum assisted fill)
- HIGH TEMPERATURE (212F/100C)

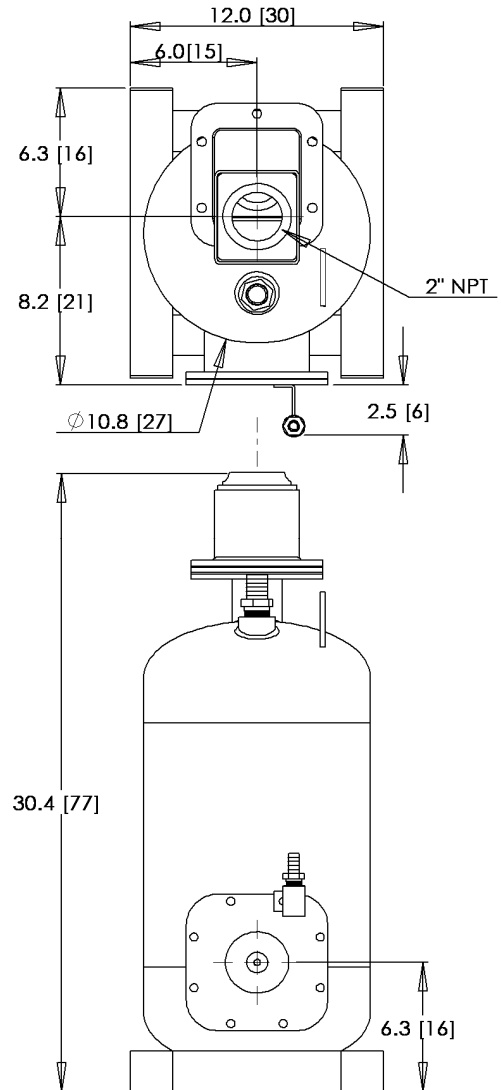

APPLICATION EXAMPLES

Sumps for: chemical process and wastewater, acid and caustic wash-down sumps, grain processing waste, tank farms, secondary containment, solvents and extraction fluids, coal yards/belts, mining solids, packing plant waste, chicken offals, blood, boiler blow down, hot tallow, remote compressor stations, boiler blow down, solvents/oils.

This pump will handle debris ranging from stringy to abrasive up to 2" diameter including slurries.

QUICK SPECS

- Weight: 96 lbs [43.5 kg]
- Stroke Volume: 5.4 gal [21 l]
- Operating Levels: 'Flow Induced' - 10" [25 cm], 'Gravity' - 24" [61 cm] (see reverse side for explanation)
- Panel Required: either AP300 or EP250

See reverse side for Specification Details, Flow Curve and Air Consumption

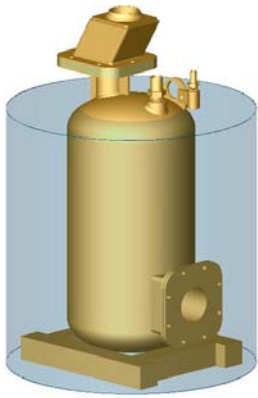

Gravity operation requires an operating level equal to the top of the pump (appr 24").

No compressed air is required for the fill stroke.

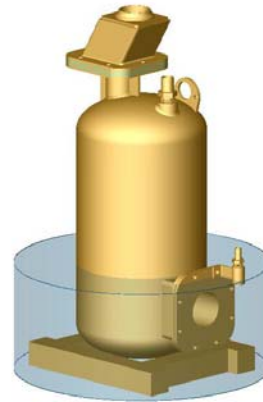

F3L flow induction uses a compressed air powered, vacuum generator mounted to the exhaust valve of the control panel. It applies vacuum to the pump during the fill stroke to lower the operating level (appr 10").

*see note below chart for additional air consumption

To specify a pump select a control panel (required) and seat option. Nitrile (std) 15 ft airlines are provided.

Part# **S3X2S/** / - - -

SEAT MATERIAL

- N = nitrile (standard)
- V = viton
- T = teflon
- UHD = hard urethane
- E = epdm
- K = kynar

PANEL OPTIONS

- AP300G3 = all-pneumatic, gravity fed.
- EP250G3 = electro-pneumatic, gravity fed.
- AP300F3L = all-pneumatic, low vacuum flow induced.
- EP250F3L = electro-pneumatic, low vacuum flow induced.

Example:

S3X2S/N/AP300G3 = 3X2" 304SS submersible pump with nitrile seats, AP300G3 control panel.

Panel Requirements: Compressed air or dry gas, unlubricated, recommended 80 psi delivered through 3/4" pipe or equal (applies to all panels).

EP250 panels also require 110 vac (<1 A).

Valve seat selection:

- Nitrile - good all-purpose elastomer. Medium chemical, oil and solvent resistance, used up to 150°F.
- Viton - excellent resistance to oxidizers and solvents. Medium strength, used up to 250°F.
- Teflon - excellent chemical resistance to acids, bases and solvents. Lower cycle life, non-elastomeric, used up to 300°F.
- Hard Urethane - high durometer with good abrasion resistance with mild chemical resistance, used up to 150°F.
- EPDM - good heat and acid/base resistance but poor hydrocarbon resistance, used up to 300°F.
- PVDF (kynar) - excellent chemical resistance, toughness and resistance to cold flow (thermoplastic). Good cycle life and can be used up to 250°F.

MAXIMUM FLOW CURVE

with air consumption in SCFM (gravity mode)

HEAD meters	5.0	10.0	15.0	20.0	25.0	30.0	35.0	40.0	45.0	50.0	55.0	60.0
220 ft 67.1	5.5	11.0	16.5	22.0	27.5	33.0	38.5	44.0	49.5	55.0	60.5	66.0
200 ft 61.0	5.1	10.1	15.2	20.3	25.3	30.4	35.4	40.5	45.5	50.5	55.5	60.5
180 ft 54.9	4.6	9.3	13.9	18.5	23.2	27.8	32.4	37.0	41.6	46.2	50.8	55.4
160 ft 48.8	4.2	8.4	12.6	16.8	21.0	25.2	29.4	33.6	37.8	42.0	46.2	50.4
140 ft 42.7	3.8	7.5	11.3	15.1	18.8	22.6	26.4	30.1	33.9	37.7	41.4	45.2
120 ft 36.6	3.3	6.7	10.0	13.3	16.7	20.0	23.3	26.7	30.0	33.3	36.7	40.0
100 ft 30.5	2.9	5.8	8.7	11.6	14.5	17.4	20.3	23.2	26.1	29.0	31.9	34.8
80 ft 24.4	2.5	4.9	7.4	9.9	12.3	14.8	17.3	19.7	22.2	24.7	27.1	29.6
60 ft 18.3	2.0	4.1	6.1	8.1	10.2	12.2	14.2	16.3	18.3	20.3	22.4	24.4
40 ft 12.2	1.6	3.2	4.8	6.4	8.0	9.6	11.2	12.8	14.4	16.0	17.6	19.2
20 ft 6.1	1.2	2.3	3.5	4.7	5.8	7.0	8.2	9.3	10.5	11.7	12.8	14.0
10 ft 3.0	1.0	1.9	2.9	3.8	4.8	5.7	6.7	7.6	8.6	9.5	10.5	11.4
GPM	5	10	15	20	25	30	35	40	45	50	55	60
lpm	19	38	57	76	95	114	132	151	170	189	208	227

Operating Flow Capacity: anywhere in shaded area.
Air consumption: pick closest cell to your flow & pressure

AP300F3L Panel



Example 1 (gravity fill): 40 gpm @ 20 ft TDH requires 9.3 scfm

*Note for flow induction: add 0.09 x gpm to the air consumption.

Example 2 (flow induced): 40 gpm @ 20 ft. Since 40 gpm @ 20 ft uses 9.3 scfm, then add 0.09 scfm per gpm to that air consumption; in this case 40 x 0.09 scfm or 3.6 scfm. The total consumption is 9.3 + 3.6 = 12.9 scfm.