



MODEL S8C

CLASS: Submersed solids handling

CONSTRUCTION: Carbon Steel

CAPACITY: 0-375 gpm [1420 lpm]

DISCHARGE PRESSURE: 0-100 psi [6.9 Bar]

MAX SOLID: 7" [18 cm]

CONFIGURATION OPTIONS

- ALL-PNEUMATIC CONTROL (XP/explosion-proof and remote locations)
- ELECTRO-PNEUMATIC CONTROL (non-XP)
- GRAVITY FILLED
- FLOW INDUCED (vacuum assisted fill)
- HIGH TEMPERATURE (212F/100C)

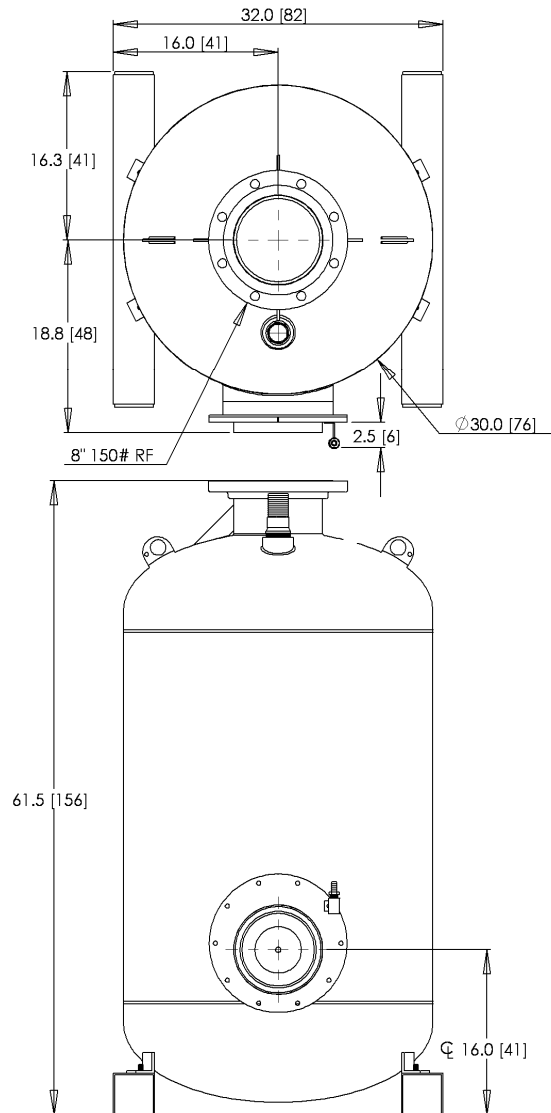

APPLICATION EXAMPLES

Sumps for: process waste, coal handling and belt conveyor sumps, bottom ash and clinker sumps, muds, wood yard and pulp sumps, foundry sand, packing plant waste, poultry offals, feathers, fruit and vegetable processing waste, XP locations, mill scale, raw sewage.

This pump will handle debris ranging from stringy to abrasive up to 7" diameter including slurries.

QUICK SPECS

- Weight: 415 lbs [188 kg]
- Stroke Volume: 66 gal [9.8 l]
- Operating Levels: 'Flow Induced' - 21" [53 cm], 'Gravity' - 55" [140 cm] (see reverse side for explanation)
- Panel Required: either AP300, EP250 or SP310

See reverse side for Specification Details, Flow Curve and Air Consumption

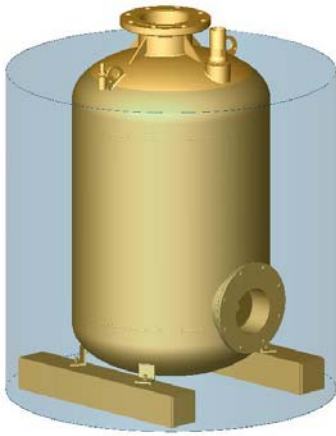

Gravity operation requires an operating level equal to the top of the pump (appr 55”).

No compressed air is required for the fill stroke.

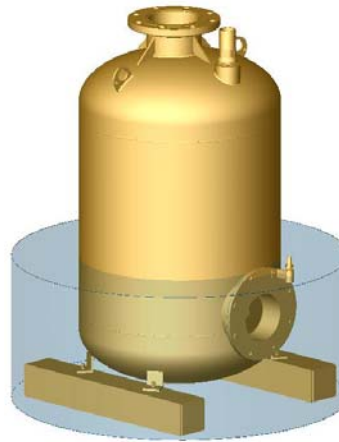

F8L flow inducement uses (2) compressed air powered, vacuum generators mounted to the exhaust valve of the control panel. They apply vacuum to the pump during the fill stroke to lower the operating level (appr 21”).

*see note below chart for additional air consumption

Part# **S8C / - / - -**

To specify a pump select a control panel (required) and seat option. Nitrile (std) 15 ft airlines are provided.

SEAT MATERIAL

- N = nitrile (standard)
- V = viton
- T = teflon
- UHD = hard urethane
- E = epdm
- K = kynar

PANEL OPTIONS

- AP300G8 = all-pneumatic, gravity fed
- EP250G8 = electro-pneumatic, gravity fed
- AP300F8L = all-pneumatic, low vacuum flow induced
- EP250F8L = electro-pneumatic, low vacuum flow induced
- SP310G8 = single probe, gravity fed
- SP310F8 = single probe, high vacuum flow induced

Example:

S8C/N/AP300G8 = 8” steel submersible pump with nitrile seats, AP300G8 control panel.

Panel Requirements:

Compressed air or dry gas, unlubricated, recommended 80 psi delivered through 2” pipe or equal (applies to all panels).

EP250 and SP310 panels also require 110 vac (<1 A).

Valve seat selection:

- Nitrile - good all-purpose elastomer. Medium chemical, oil and solvent resistance, used up to 150°F.
- Viton - excellent resistance to oxidizers and solvents. Medium strength, used up to 250°F.
- Teflon - excellent chemical resistance to acids, bases and solvents. Lower cycle life, non-elastomeric, used up to 300°F.
- Hard Urethane - high durometer with good abrasion resistance with mild chemical resistance, used up to 150°F.
- EPDM - good heat and acid/base resistance but poor hydrocarbon resistance, used up to 300°F.
- PVDF (kynar) - excellent chemical resistance, toughness and resistance to cold flow (thermoplastic). Good cycle life and can be used up to 250°F.

MAXIMUM FLOW CURVE

with air consumption in SCFM (gravity mode)

HEAD meters	44	88	132	176	220	264	Operating Flow Capacity: <i>anywhere in shaded area.</i> Air consumption: pick closest cell to your flow & pressure match											
220 ft 67.1	44	88	132	176	220	264	280	320	360	400	440	480	211	241	271	301	331	361
200 ft 61.0	41	81	122	162	203	243	280	320	360	400	440	480	187	213	240	267	293	320
180 ft 54.9	37	74	111	148	185	222	280	320	360	400	440	480	162	186	209	232	255	278
160 ft 48.8	34	67	101	134	168	202	280	320	360	400	440	480	138	158	178	197	217	237
140 ft 42.7	30	60	90	120	151	181	280	320	360	400	440	480	114	130	146	163	179	195
120 ft 36.6	27	53	80	107	133	160	280	320	360	400	440	480	90	102	115	128	141	154
100 ft 30.5	23	46	70	93	116	139	280	320	360	400	440	480	65	75	84	93	103	112
80 ft 24.4	20	39	59	79	99	118	280	320	360	400	440	480	53	61	69	76	84	91
60 ft 18.3	16	33	49	65	81	98	280	320	360	400	440	480	46	53	61	69	76	84
40 ft 12.2	13	26	38	51	64	77	280	320	360	400	440	480	46	53	61	69	76	84
20 ft 6.1	9	19	28	37	47	56	280	320	360	400	440	480	46	53	61	69	76	84
10 ft 3.0	8	15	23	30	38	46	280	320	360	400	440	480	46	53	61	69	76	84
GPM	40	80	120	160	200	240	280	320	360	400	440	480						
lpm	151	303	454	606	757	908	1060	1211	1363	1514	1665	1817						

SP310F6 Panel



Example 1 (gravity fill): 320 gpm @ 20 ft TDH requires 75 scfm

*Note for flow inducement: add 0.18 x gpm to the air consumption (using F8L).

Example 2 (flow induced): 320 gpm @ 20 ft. Since 320 gpm @ 20 ft uses 75 scfm, then add 0.18 scfm per gpm to that air consumption; in this case 320 x 0.18 scfm or 58 scfm. The total consumption is 75 + 58 = 133 scfm.