



MODEL T3C

CLASS: Transfer solids handling

CONSTRUCTION: Carbon Steel

CAPACITY: 0-49 gpm [185 lpm]

DISCHARGE PRESSURE: 0-100 psi [6.9 Bar]

MAX SOLID: 3" [7.6 cm]

CONFIGURATION OPTIONS

- ALL-PNEUMATIC CONTROL (XP/explosion-proof and remote locations)
- ELECTRO-PNEUMATIC CONTROL (non-XP)
- GRAVITY FILLED
- FLOW INDUCED (vacuum assisted fill)
- HIGH TEMPERATURE (212F/100C)

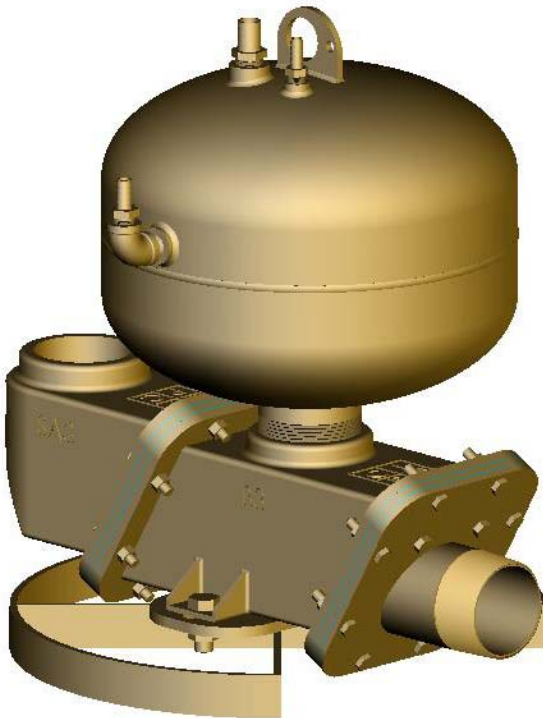
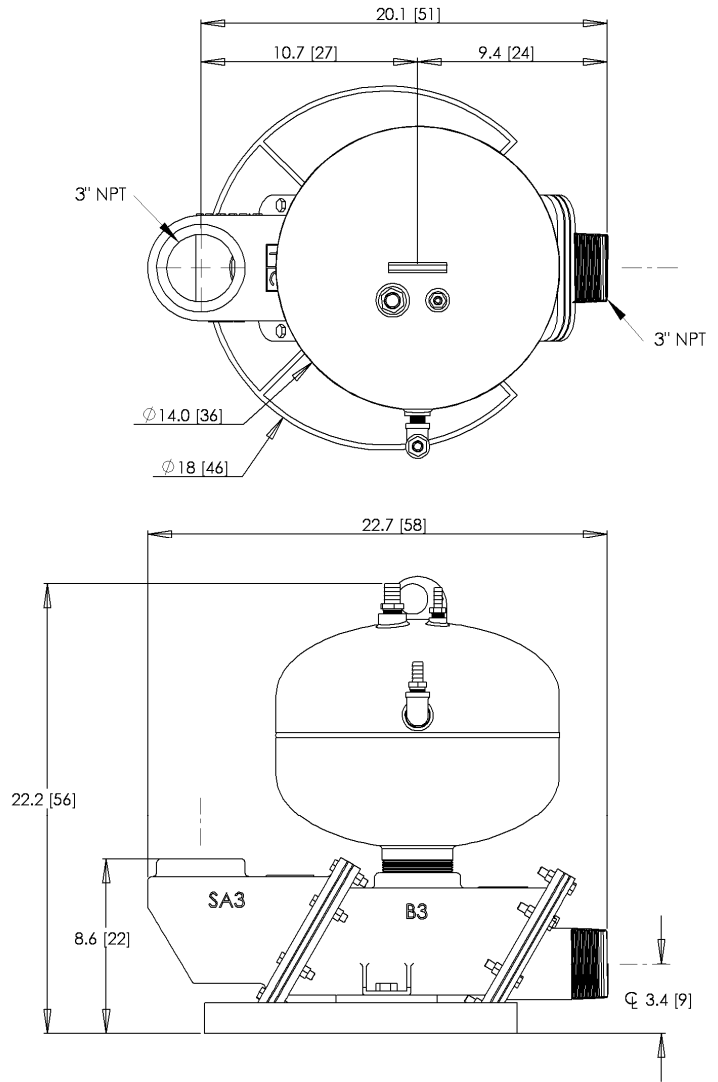

APPLICATION EXAMPLES

Process and wastewater handling, clarifier sludge, diatomaceous earth slurry, sewage, secondary containment, drilling muds, solvents and extraction fluids, evaporator/vacuum distillers, knockout pots, packing plant wastes, boiler blow down, DAF sludge, oil/water separators, lapping compound.

This pump will handle debris ranging from stringy to abrasive up to 3" diameter including slurries.

QUICK SPECS

- Weight: 82 lbs [35 kg]
- Stroke Volume: 5.2 gal [20 l]
- Operating Levels: 'Gravity' - 18" [30 cm]
Optional Suction Lift: 'Flow Induced' - 120" [3 m] maximum suction lift
(see reverse side for explanation details)
- Panel Required: either AP212 or SP310

See reverse side for Specification Details, Flow Curve and Air Consumption

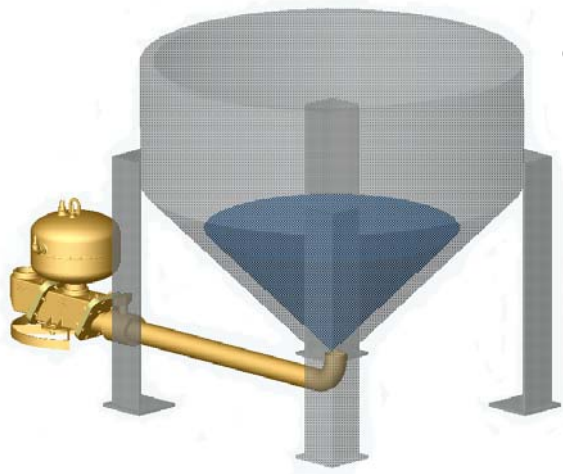

Gravity operation (left) requires an operating level equal to or above the top of the pump (appr 18" above grade).
No compressed air is required for the fill stroke.

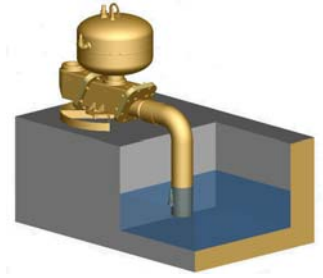

F3 flow inducement (above right) uses an air powered, vacuum generator on the exhaust valve of the control panel. It applies vacuum to the pump during the fill stroke to pull fluid up into the pump; 10 ft of lift is the recommended maximum.
*see note below chart for additional air consumption

Part# **T3C/_/_/_**

To specify a pump select a control panel (required) and seat option. Nitrile (std) 15 ft airlines are provided.

SEAT MATERIAL

- N = nitrile (standard)
- V = viton
- T = teflon
- UHD = hard urethane
- E = epdm
- K = kynar

PANEL OPTIONS

- AP212G3 = all-pneumatic, gravity fed.
- SP310G3 = single probe, gravity fed.
- AP212F3 = all-pneumatic, flow induced.
- SP310F3-LLC = single probe, flow induced with level control.

Example:

T3C/N/AP212G3 = 3" steel transfer pump with nitrile seats, AP212G3 control panel.

Panel Requirements: Compressed air or dry gas, unlubricated, recommended 80 psi delivered through 3/4" pipe or equal (applies to all panels).

SP310 panels also require 110 vac (<1 A).

Valve seat selection:

- Nitrile - good all-purpose elastomer. Medium chemical, oil and solvent resistance, used up to 150°F.
- Viton - excellent resistance to oxidizers and solvents. Medium strength, used up to 250°F.
- Teflon - excellent chemical resistance to acids, bases and solvents. Lower cycle life, non-elastomeric, used up to 300°F.
- Hard Urethane - high durometer with good abrasion resistance with mild chemical resistance, used up to 150°F.
- EPDM - good heat and acid/base resistance but poor hydrocarbon resistance, used up to 300°F.
- PVDF (kynar) - excellent chemical resistance, toughness and resistance to cold flow (thermoplastic). Good cycle life and can be used up to 250°F.

MAXIMUM FLOW CURVE

with air consumption in SCFM (gravity mode)

HEAD meters	5	10	15	20	25	30	35	40	45	50	55	60	
220 ft	67.1	5.5	11.0	16.5	22.0	27.5	33.0	38.5	Operating Flow Capacity: anywhere in shaded area.				
200 ft	61.0	5.1	10.1	15.2	20.3	25.3	30.4	35.4	Air consumption: pick closest cell to your flow & pressure				
180 ft	54.9	4.6	9.3	13.9	18.5	23.2	27.8	32.4	30.1	33.9	37.7	41.4	45.2
160 ft	48.8	4.2	8.4	12.6	16.8	21.0	25.2	29.4	26.7	30.0	33.3	36.7	40.0
140 ft	42.7	3.8	7.5	11.3	15.1	18.8	22.6	26.4	23.2	26.1	29.0	31.9	34.8
120 ft	36.6	3.3	6.7	10.0	13.3	16.7	20.0	23.3	19.7	22.2	24.7	27.1	29.6
100 ft	30.5	2.9	5.8	8.7	11.6	14.5	17.4	20.3	16.3	18.3	20.3	22.4	24.4
80 ft	24.4	2.5	4.9	7.4	9.9	12.3	14.8	17.3	12.8	14.4	16.0	17.6	19.2
60 ft	18.3	2.0	4.1	6.1	8.1	10.2	12.2	14.2	9.3	10.5	11.7	12.8	14.0
40 ft	12.2	1.6	3.2	4.8	6.4	8.0	9.6	11.2	7.6	8.6	9.5	10.5	11.4
20 ft	6.1	1.2	2.3	3.5	4.7	5.8	7.0	8.2					
10 ft	3.0	1.0	1.9	2.9	3.8	4.8	5.7	6.7					
GPM	5	10	15	20	25	30	35	40	45	50	55	60	
lpm	19	38	57	76	95	114	132	151	170	189	208	227	

SP310F3-LLC Panel



Example 1 (gravity fill): 30 gpm @ 20 ft TDH requires 7 SCFM

*Note for flow inducement: add 0.22 x gpm to the air consumption.

Example 2 (flow induced): 30 gpm @ 20 ft using suction lift. Since 30 gpm at 20 ft uses 7 scfm (from chart), then add 0.22 scfm per gpm to the consumption; in this case 30 x 0.22 or 6.6 scfm. The total consumption is 7+6.6=13.6 scfm.